



SAN YA Planetary Reducers

三亞牌 遊星式減速機



結構

Structure

高效率
低背隙
高扭力
耐衝擊
體積小
重量輕

High Efficiency
Low Clearance
High Torque Force
Impact Resistant
Small Size
Light Weight

本產品依據AGMA標準製造，適用於每日24小時連續運轉。

The products are manufactured per AGMA standards and are able to be operated 24 hours a day continuously.

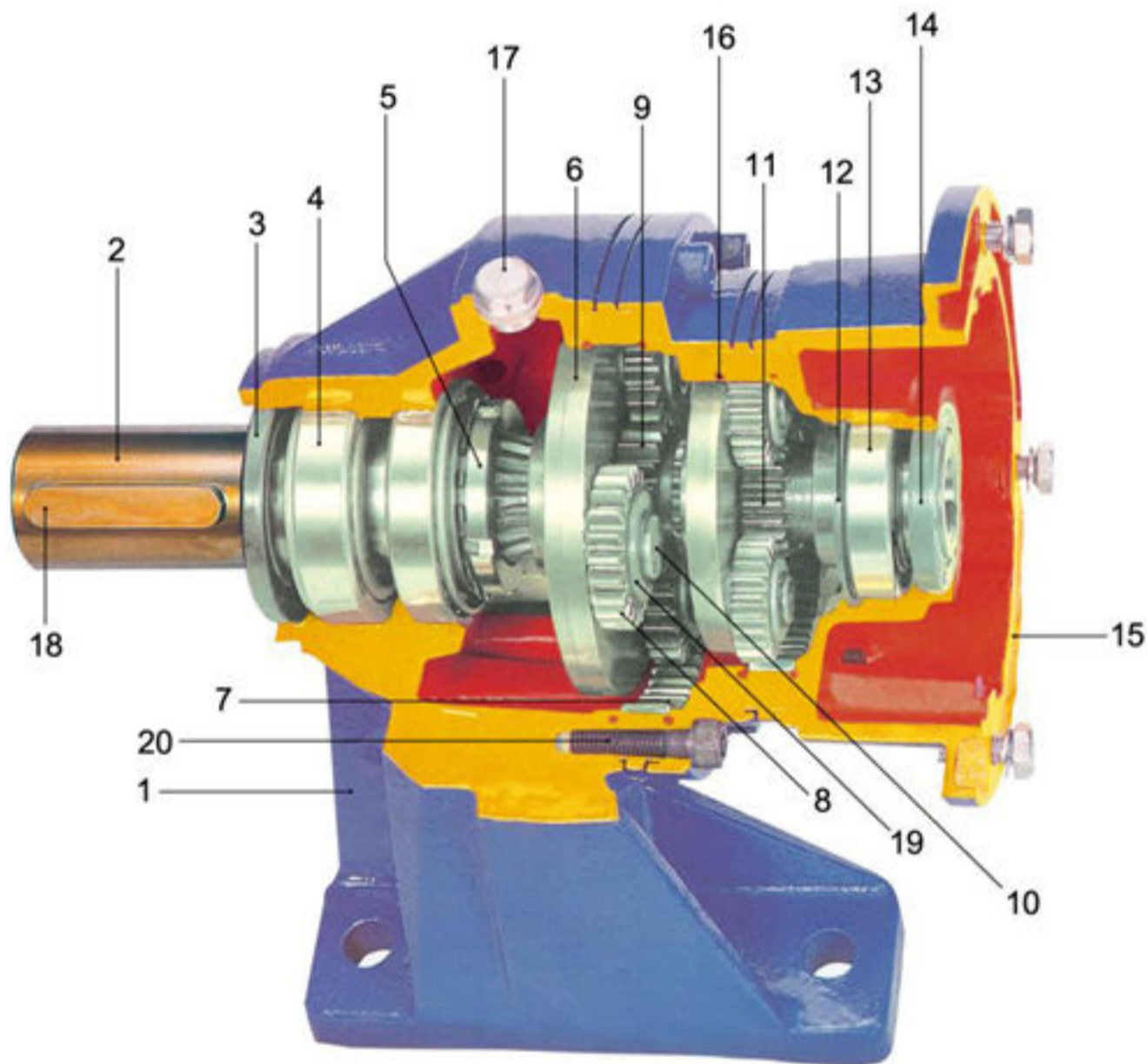

零件 Parts List

1. 本體	Housing	11. 太陽齒輪	Sun Gear Input Shaft
2. 出力軸	Output Shaft	12. C型扣環	Snap Ring
3. 出力軸油封	Oil Seal-Output Shaft	13. 入力軸承	Bearing-Input Shaft
4. 出力軸承	Bearing-Output Shaft	14. 入力軸油封	Oil Seal-Input Shaft
5. 太陽螺帽	Sun Nut	15. 入力法蘭	Input Flange
6. 遊星架	Planetary Carrier	16. O型環	O-Ring
7. 內齒環	Internal Gear Ring	17. 透氣塞	Breather Plug
8. 遊星齒輪	Planetary Gear	18. 鍵	Key-Output Shaft
9. 階段齒輪	Using Connected Section's Gear	19. 墊圈	Washer
10. 滾針軸	Needle Roller Pin	20. 六角承窩螺絲	Hex Socket Cap Screw

行星減速機之段數組合圖

Staged assembly drawings of planetary speed reducers

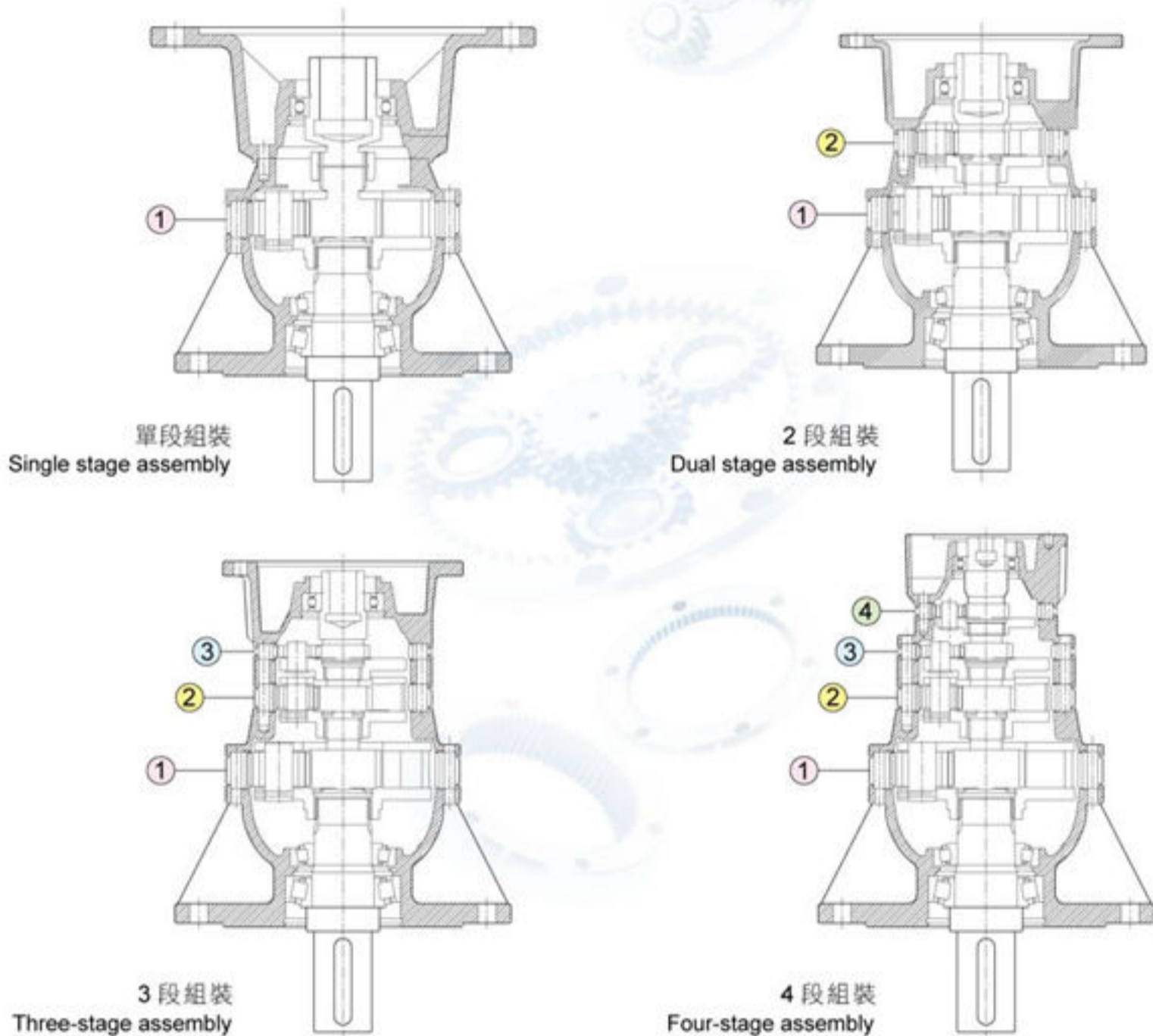

行星減速機齒輪零件材質表 Bill of Materials of the planetary speed reducer gears

型號 Model Number	本體 Housing	出力軸 Output Shaft	行星架 Planetary Carrier	滾針軸 Roller Pin Shaft	內齒輪環 Internal GearRing	行星齒輪 Planetary Gear	階段齒輪 Interconnecting Gear	太陽齒輪 Sun Gear
200	FC25	■ SCM440	FCD45	■ SNCM220	S45C	■ SCM415	■ SCM415	■ SCM415
280	FC25	■ SCM440	FCD45	■ SNCM220	SCM440	■ SCM415	■ SCM415	■ SCM415
300 (H)	FC25	■ SCM440	FCD45	■ SNCM220	■ SCM440	■ SCM415	■ SCM415	■ SCM415
301 (H)	FC25	■ SCM440	FCD45	■ SNCM220	■ SCM440	■ SCM415	■ SCM415	■ SCM415
303	FC25	■ SCM440	FCD45	■ SNCM220	■ SCM440	■ SCM415	■ SCM415	■ SCM415
305	FC25	■ SCM440	FCD45	■ SNCM220	■ SCM440	■ SCM415	■ SCM415	■ SCM415
307	FC25	■ SCM440	FCD45	■ SNCM220	■ SCM440	■ SCM415	■ SCM415	■ SCM415
309	FC25	■ SCM440	FCD45	■ SNCM220	■ SCM440	■ SCM415	■ SCM415	■ SCM415
313	FCD45	■ SCM440	FCD45	■ SNCM220	■ SCM440	■ SCM415	■ SCM415	-

* 熱處理符號代表 Heat treatment markings

■ 調質 Quenching and Tempering ■ 高周波 High Frequency ■ 滲碳 Carburizing

結構 Structure

行星減速機傳動原理

行星減速機之傳動結構為目前齒輪減速機效率最高之組合，其基本傳動結構為：

- (A) 太陽齒輪。 (B) 行星齒輪 (組合於行星架)。
(C) 內齒輪環。 (D) 階段齒輪。

驅動源以直結或連接方式啟動太陽齒輪，太陽齒輪將組合於行星架上之行星齒輪帶動運轉。整組行星齒輪系統沿著外齒輪環自轉繞行轉動，行星架連結出力軸輸出達到減速目的。更高減速比則藉由多組階段齒輪與行星齒輪倍增累計而成。

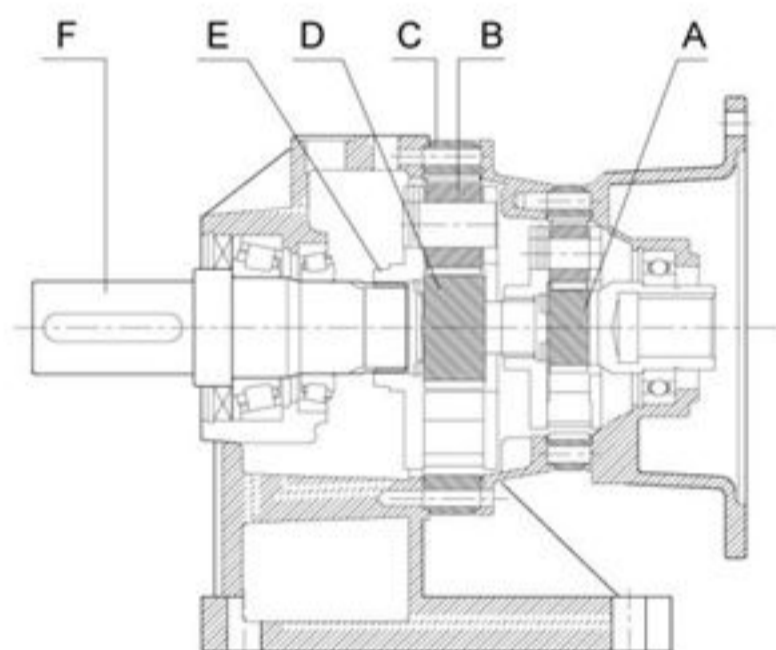

Transmission Principle of Planetary Speed Reducer

The transmission structure of the planetary speed reducer has the highest geared speed reducer efficiency among all the combinations. Its basic transmission structure includes:

- (A) Sun Gear, (B) Planetary Gear (assembled with the planetary carrier),
(C) Internal GearRing, (D) Staging Gear

The driving power through direct connection or link initiates the sun gear. The sun gear then drives the planetary gears assembled with the external gear ring to operate. The whole set of planetary gear system revolves on its own axis and along the external gear ring, where the output shaft connected to the planetary carrier achieves the goal of speed reduction. A higher reduction ratio can be achieved by doubling the multiple staged gears and planetary gears.

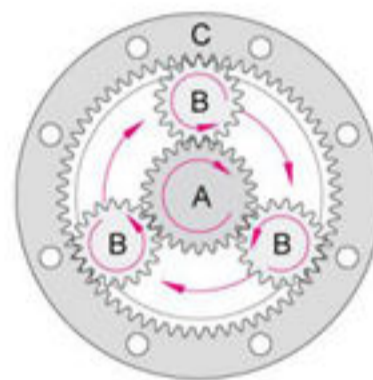

A	太陽齒輪	Sun Gear
B	行星齒輪	Planetary Gear
C	內齒輪環	Internal GearRing
D	連接齒輪	Using Connected Section's Gear
E	行星架	Planetary Carrier
F	出力軸	Output Shaft

行星齒輪減速機之特性

■ **高扭力、耐衝擊：**行星齒輪之結構異同於傳統平行齒輪之運動方式。傳統齒輪僅依靠兩個齒輪間極少數點接觸面擠壓驅動，所有負荷集中於相接觸之少數齒輪面(圖一)，容易產生齒輪之磨擦與斷裂。而行星減速機具有六個更大面積齒輪接觸面360度均布負荷(圖二)，多個齒輪面共同均勻承受瞬間衝擊負荷，使其更能承受較高扭力之衝擊，本體及各軸承零件亦不因高負荷而損壞破裂。

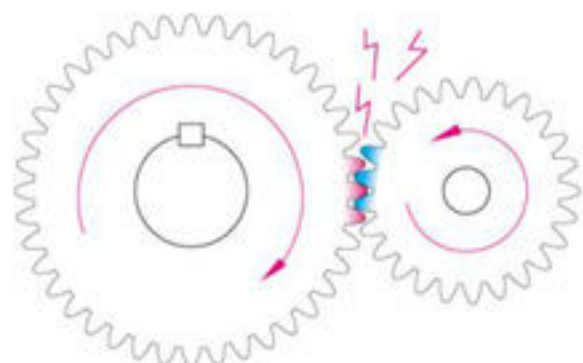

(圖一)：齒輪咬合
(Figure 1) : Gear Engagement Gear Conjunction

Characteristics of Planetary Speed Reducer

High torque, impact resistance: The method of motion of a planetary gear structure is different from traditional parallel gears. Traditional gears rely on a small number of contact points between two gears to squeeze as the driving force, where all the loadings are concentrated on a few contacting surfaces (Figure 1), making it easy to wear and crack the gears. But the planetary speed reducer has six gear contacting surfaces with a larger area that can distribute the loading evenly over 360 degrees (Figure 2). Multiple gear surfaces share the instantaneous impact loading evenly which make them more resistant to the impact from higher torques. The housing and bearing parts will not be damaged and crack due to high loading, either.

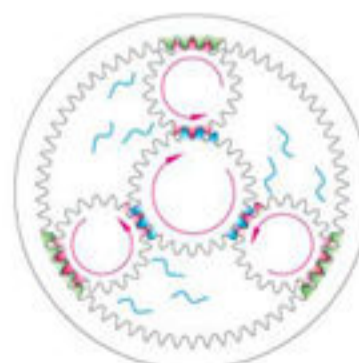

(圖二)：行星齒輪咬合
(Figure 2) : Planetary Gear Engagement
Planetary Gear Conjunction

■ **體積小、重量輕**：傳統齒輪減速機之設計皆藉由多組大小齒輪偏向交錯傳動減速，由於減速比需由兩個齒輪數之倍數值產生，大小齒輪間更要有一定之間距咬合，因此齒箱容納空間極大；尤其高減速比的組合時更需要由兩台以上減速齒箱連接組合，結構強度相對變弱，更使齒箱長度加長，造成體積與重量極為龐大。行星減速機的结构可依需求段數重複連結，單獨完成多段組合，體積小、重量輕、外觀輕巧，相形使設備更有價值感。

Small volume and lightweight: traditional design of geared speed reducers typically applies multiple sets of large and small gears to operate in a staggered pattern for power transmission and speed reduction. Because the reduction ratio needs to be generated by the multiples of tooth numbers of the two gears, there must be a certain engaging clearance between large and small gears. Therefore, the required space for the gearbox is relatively large. Especially for the combination of a high-speed reduction ratio, which needs a combination of more than two gearboxes and for which its structural strength will become relatively weak and enlarge its gearbox length, causing extremely large volume and weight. The structure of a planetary speed reducer can be designed for repeated connection according to the required number of stages and realizes the multiple staged combination alone. Its small volume, light weight and compact outline make the equipment look more valuable.

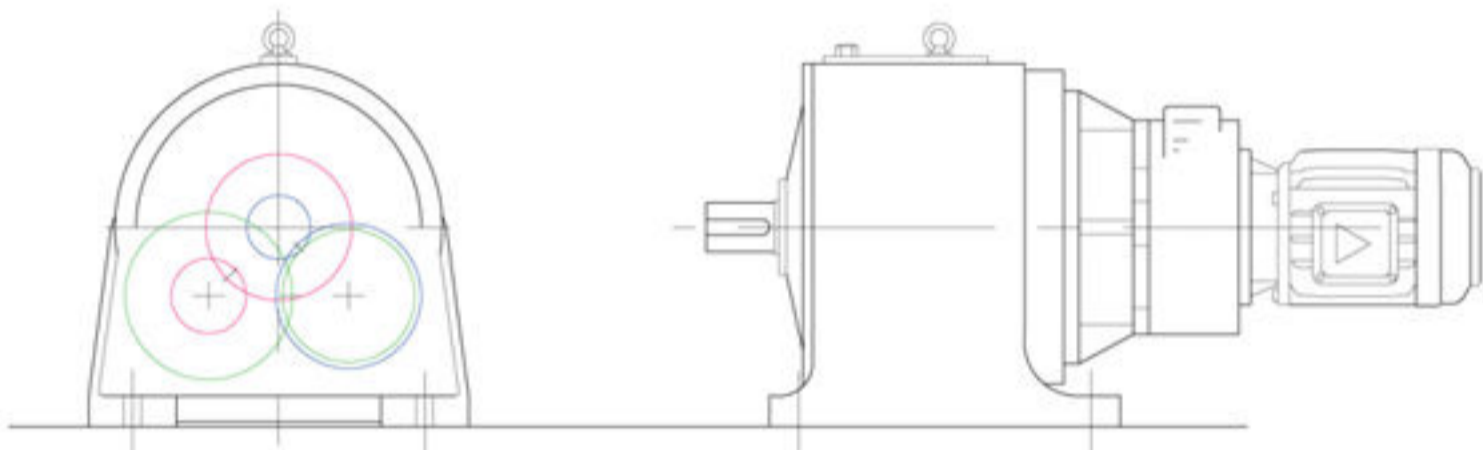

齒輪減速機 (Geared Speed Reducer)

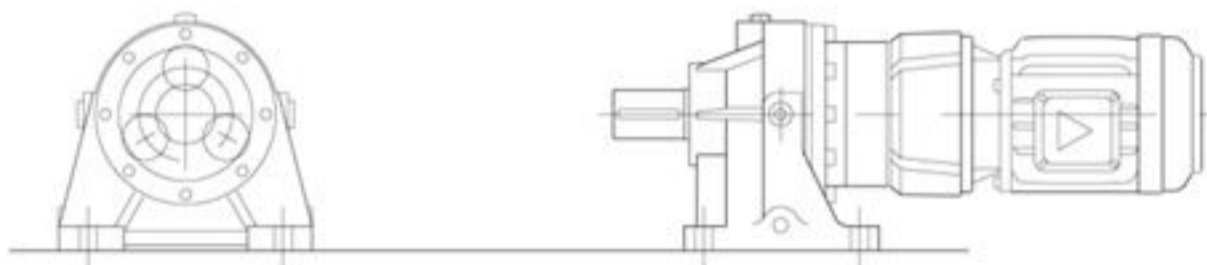

行星齒輪減速機 (Planetary Speed Reducer)

■ **高效率、低背隙**：由於齒輪減速機每一組齒輪減速傳動時只有單齒面咬合接觸，當傳動相等扭力時需要更大的齒面應力，因此齒輪設計時必須採用更大之模數與厚度，齒輪模數越大將造成齒間偏轉公差值變大，相對形成較高齒輪間隙，各段減速比間的累計背隙隨之增加。而行星齒輪組合中特有的多點均勻密合，外齒輪環的圓弧包絡結構，使外齒輪環與行星齒輪間緊密結合，齒輪間密合度高，除了提升極高之減速機效率值外，設備本身更可達到高精度定位選用。

High efficiency and low back clearance: Because there is only a single tooth surface engaged and contacted when each set of gears operates to reduce speed, the stress on the tooth surface should be larger when transmitting the same torque. Therefore, the gear design should apply larger module and thickness. The larger the module is, the larger the deviation tolerance between gear teeth, which creates a relatively large gear clearance and increases the accumulated back clearance for each stage of speed reduction. The unique characteristic of uniform engagement of the planetary gear combination and arc enveloping structure of the external gear ring help with the robust engagement between the external gear ring and planetary gear. With the highly robust engagement between gears, apart from improving the extremely high-speed reducer efficiency, the equipment itself can be selected to meet the requirements of positioning in high precision.

比數與組合

Gear ratio and combination

行星齒輪減速原理與比速計算

行星減速機比數之簡易計算方法：當階段齒輪或太陽齒輪 (A) 轉動一定轉速，行星齒輪 (B) 繞行內齒輪環 (C) 一圈回到原點，其轉速即為該單段減速比。由於同型號之內齒輪環皆為共用，故減速比之高低係由太陽齒輪齒數決定，太陽齒輪數越少減速比越高(圖一)，反之太陽齒輪數越多，則減速比越小(圖二)。其實際計算方式為內齒環齒數除以太陽齒輪齒數；所得數字加固定係數1，該值即為減速比。各單段比數相成即為該機總比數。

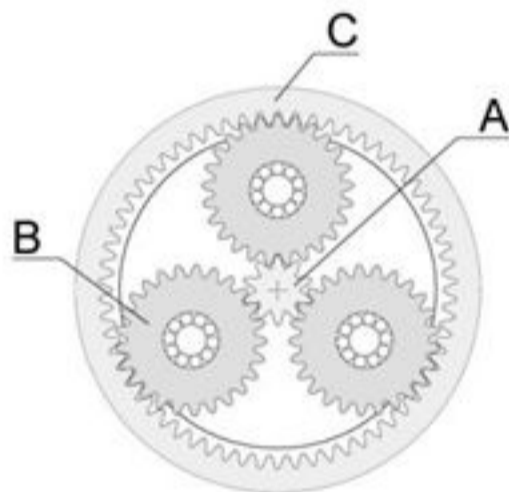

(圖一) 高減速比

單段減速比 (i) 之計算方式 $i = C + A + 1$

(Figure 1) High reduction ratio

Calculation of a single reduction ratio (i)

$$i = C + A + 1$$

行星減速機之拆解與傳動元件之搭配

行星減速機之行星架採用浮動式內置於減速機中，拆解零件及更換比數時只需局部取出部份零件更換，無須大部拆解造成零件受損。安裝法蘭採用國際標準規格直接式連結，客戶可自行選用不同廠牌或特殊防護等級需求之馬達安裝。本公司亦提供各種特殊連結法蘭，如同服、直流、油壓、氣動、渦輪、變速機等。



渦輪減速機組合
Match Worm Gear



伺服馬達組合
Match Servo Motor



變速機組合
Match Variator



氣動馬達組合
Match Air Motor

Principle of planetary gear speed reduction and calculation of gear ratio

Simple calculation method for the gear ratio of a planetary speed reducer: when step gear or sun gear (A) rotates at a certain speed, planet gear (B) travels along the internal gear ring (C) in a full round and return to the origin, where the rotation speed is the reduction ratio of that single interval. Because the internal gear ring is common to the same model number, the value of the speed reduction ratio is determined by the tooth number of the sun gear. The lower the tooth number of the sun gear, the higher the speed reduction ratio (Figure 1). On the contrary, the higher the tooth number of the sun gear, the lower the speed reduction ratio (Figure 2). The actual calculation method is to divide the tooth number of the internal gear ring by the tooth number of the sun gear. The number derived added to the fixed coefficient 1 is then the speed reduction ratio. Multiply the ratios of each single step to obtain the total reduction ratio of that machine.

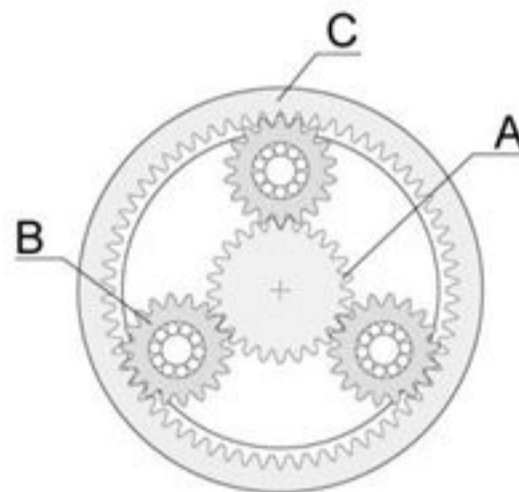

(圖二) 低減速比

多段減速比 (i) 之計算方式 $i = (C + A + 1) \times (C + A + 1) \times \dots$

(Figure 2) Low reduction ratio

Calculation of a multiple step reduction ratio (i)

$$i = (C + A + 1) \times (C + A + 1) \times \dots$$

Dismantling of the planetary speed reducer and collocation of transmission components

The planetary rack of the planetary speed reducer is floating and embedded inside the speed reducer. When disassembling parts and changing ratios, only partial removal of some of the parts is required for the replacement. There is no need to disassemble the major portion, which could cause damage to the parts. Install the flange in a direct connection, which is applied to international standard specifications. Customers can select different brands by themselves or install the motor of specific requirements for protective grades. Our company also provides specific sizes including servo, DC, hydraulic, pneumatic, turbine, speed variator, etc.

本公司為專業減速機製造廠，可協助客戶研發各種專用設備機型。針對各種特殊需求與空間搭配，可多樣性配合其他產品組裝。歡迎洽詢本公司業務人員。

Our company is a professional speed reducer manufacture capable of helping our customers with the research and development of various types of specialized equipment models. According to different needs of specific requirements and accommodation to spaces, myriad assembly combinations with other products can be adopted. You are welcome to contact our sales staff for details.



· 中空出力軸
Hollow Output Shaft



· 渦輪臥式組合
H-Type Worm Gear Combination



· 洗刀專用機
Special Machine For Milling Cutter



· 攪拌機應用(A)
Mixer Application(A)



· 氣動無段組合
Air Power Variator Combination



· 渦輪臥式組合
V-Type Worm Gear Combination



· 攪拌機應用(B)
Mixer Application(B)



· 攪拌機應用(C)
Mixer Application(C)



· 轉向器組合
Steering Gear Combination



· 特殊型減速機
Special Reducers

計算-單位轉換-係數表 *Technical*

公式及範例 Technical formula

$$HP = \frac{T \times N}{716.2}$$

HP = 馬力 Horse power (HP)
 T = 扭矩 Torque (kg-m)
 N = 迴轉數 rpm

範例：
 入力轉動馬力1HP
 減速比1/20
 設定傳動效率100%
 求其輸出扭矩To?

For example :
 Input Motor HP = 1HP
 Ratio = 1/20
 Efficiency = 100%
 The Torque To = ?

$$HP = \frac{T \times N}{716.2} \quad T = \frac{716.2}{1800} = 0.3979\text{kg-m}$$

$$To = 0.3979 \times 20 \times 100\% = 7.958\text{kg-m}$$

範例：
 已知出力軸迴轉數90 rpm，
 入力軸迴轉數1800 rpm，求其減速比？
 求其減速比？

For example :
 Ooutput Shaft rpm = 90rpm
 Input Shaft rpm = 1800rpm
 The Ratio = ?

$$R = \frac{1800}{90} = 20 \quad \text{減速比} = 20$$

$$\text{Ratio} = 20$$

單位換算

Meter(m) = inches(in) x 0.0254
Meter(m) = feet(ft) x 0.3048
Kilograms(kg) = tons(t) x 1016.047
Kilograms(kg) = pounds(lb) x 0.45359
Newton(N) = pound-force(lbf) x 4.448222
Newton metro(Nm) = pound foot(lb ft) x 1.355818
Newton metro(Nm) = Kilograms meter(Kgm) x 9.81
DaNm = Nm/10

懸垂荷重係數表 O.H.L Factor Table

鏈輪	Sprocket	1.00
齒輪	Gear	1.25
三角皮帶	V-Belt	1.50
平皮帶	Flat-Belt	2.50

荷重係數表 Load Factor Table

原動機 Prime Machine	傳動機荷重等級 Driven Machine Load Classification	每日使用時間 Duration Of Service Per Day			
		Occasional 0.5hr.	Intermittent 2hr.	8-10hrs	10-24hrs
電動機 Electric Motor	均一負荷 Uniform	0.80	0.90	1.00	1.25
	中衝擊 Medium Shock	0.90	1.00	1.25	1.5
	重衝擊 Heavy Shock	1.00	1.25	1.50	1.75

Efficiency and Oil 效率與潤滑油脂

遊星齒輪減速機的效率表

段數 Stage	減速比 Reduction Ratio	效率值 Efficiency
L1	3.48 ~ 7.2	97%
L2	12.1 ~ 51.8	95%
L3	63 ~ 373	92%
L4	403 ~ 2687	90%

Efficiency

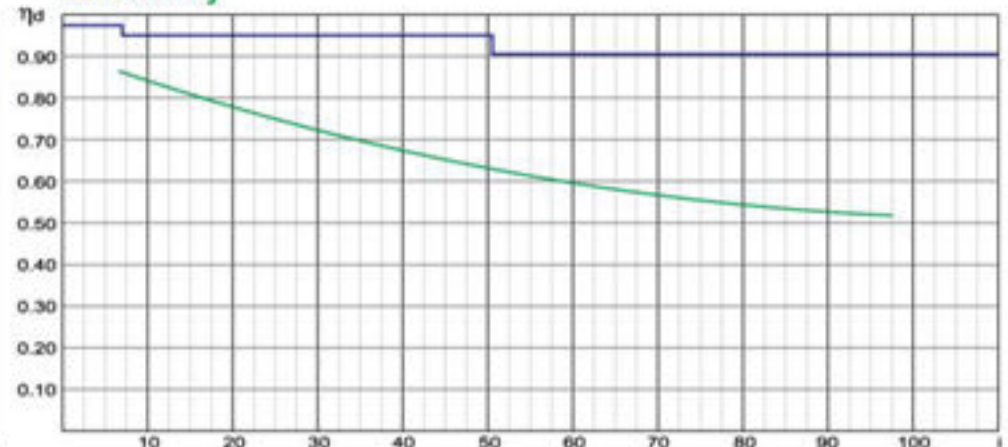

η_d : 表示傳輸效率

Transmission efficiency

i : 表示減速比數

Reduction ratio

—: 表示遊星式齒輪減速機效率值

Efficiency of planetary gear

—: 表示傳統式齒輪減速機效率值

Efficiency of helical gear

潤滑油選定

適當潤滑油的黏度，可使齒輪滑動摩擦圓滑，於高負荷及衝擊負荷時，減速機才能充分發揮應有之效率。

Gear lubrication

Suitable gear lubrication oil will increase gear surface contact running and extension gears, bearings & other parts life. Please reference following table of lubrication gear oil for your reducers.

下表即減速機潤滑的選定 Gear lubrication

荷重 LOAD	周圍溫度 AMBIENT	SHELL OIL	MOBIL OIL	中國石油
普通荷重 Normal Load	-30°C~5°C	Omala oil 68	Mobil Comp 629	國光牌極壓機油 HD-68
	5°C~40°C	Omala oil R220	Mobil Comp 632 600W Cylinder oil	國光牌極壓機油 HD-220
	40°C~65°C	Omala oil R320	Mobil Comp 634 600W Cylinder oil	國光牌極壓機油 HD-320
重級荷重 Heavy Load	-30°C~5°C	Omala oil 150	Mobil Comp 632	國光牌極壓機油 HD-150
	5°C~40°C	Omala oil R320	Mobil Comp 634	國光牌極壓機油 HD-320
	40°C~65°C	Omala oil R68	Mobil Comp 636	國光牌極壓機油 HD-680

注意事項

- ※ 適當的潤滑油黏度，可使齒輪磨擦容易，則高負荷及衝擊負荷時，減速機才能充分發揮其機能。
- ※ 本產品出廠之減速機皆使用國光牌極壓機油HD-320。
- ※ 最初使用300小時後，需換上新油，其後每2500小時更換潤滑油。
- ※ 使用環境在高溫、高速、低速、重負荷、強制潤滑等特殊情況時，請向本公司提示。
- ※ 潤滑油不足可能導致齒輪快速磨損和效率降低。
- ※ 潤滑油過多可能導致漏油及溢出現象，請加入適當潤滑油至油面計一半以上。

Remark

- ※ Appropriate viscosity of the lubricant will make the gears engage much easier. Such would then help the speed reducers to fully exploit its performance for heavy loading and impact loading.
- ※ All speed reducers equipped with products by Sanya all apply CPC E.P. Lubricant HD-320
- ※ After the first use of 300 hours, new oil should be replaced, lubricant should be replaced for every 2,500 hours following the first oil change.
- ※ Please remind our company of the special conditions of the operating environment including high temperature, high speed, low speed, heavy loading, forced lubrication etc.
- ※ Insufficient lubrication could result in quick wear-out of gears and low efficiency.
- ※ Excessive lubrication can result in oil leaking. Please fill with an appropriate amount of lubricant more than half of the oil level gage.

馬達尺寸圖

Motor Dimension

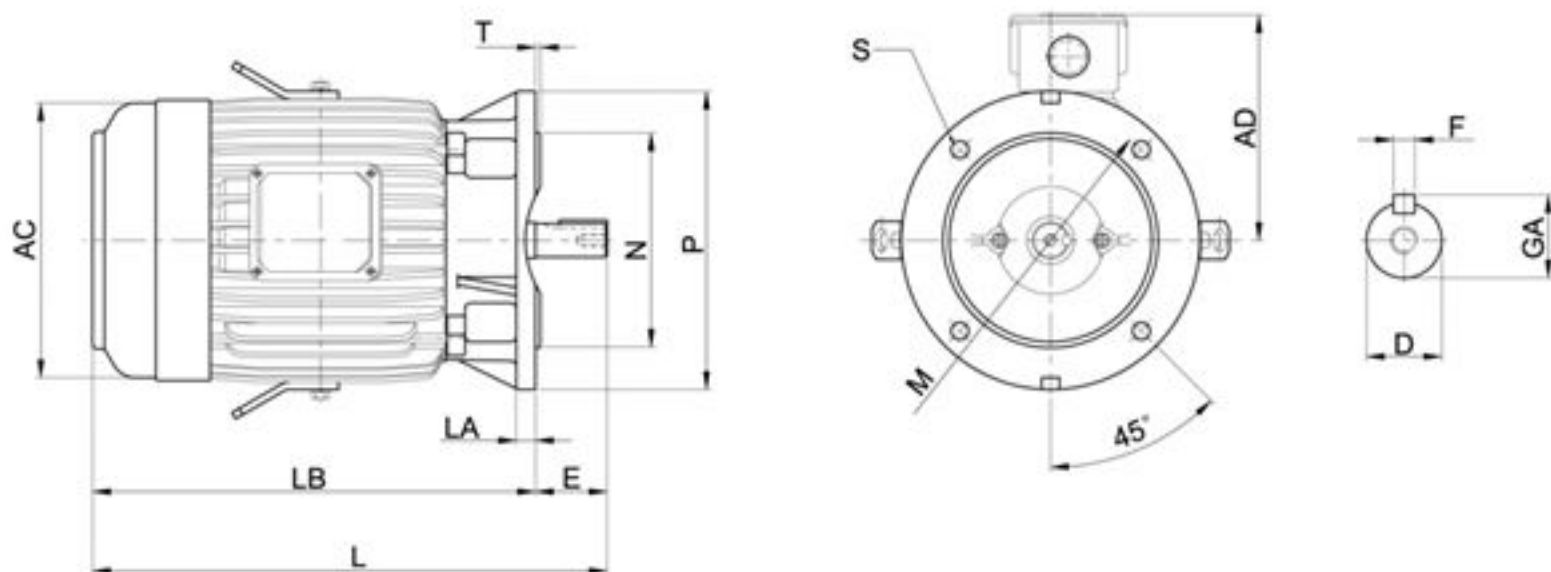

馬達尺寸圖 (參考尺寸) Motor Dimension

單位:(mm)

輸出馬力 (HP)			框號	AC	AD	L	LA	LB	E	M	N	P	D	S	T	F	GA
2P	4P	6P															
0.25	0.25	—	63	144	123	248.0	12	225.0	23	130	110	160	11	10.0	3.5	4	12.5
0.5	0.5	—	71	162	133	277.5	12	247.5	30	130	110	160	14	10.0	3.5	5	16.0
1	1	0.5	80	177	144	282.0	12	242.0	40	165	130	200	19	12.0	3.5	6	21.5
2, 3	2	1	90L	200	157	371.5	12	321.5	50	165	130	200	24	12.0	3.5	8	27.0
—	3	2	100L	219	180	374.5	16	314.5	60	215	180	250	28	14.5	4.0	8	31.0
5	5	3	112M	235	189	431.0	16	371.0	60	215	180	250	28	14.5	4.0	8	31.0
7.5, 10	7.5	5	132S	273	224	454.0	20	374.0	80	265	230	300	38	14.5	4.0	10	41.0
—	10	7.5	132M			492.0		412.0									
15, 20	15	10	160M	334	263	608	20	498	110	300	250	350	42	18.5	5.0	12	45.0
25	20	15	160L			652		542									
30	—	—	180MA	382	305	672	20	562	110	350	300	400	48	18.5	5.0	14	51.5
—	25, 30	20	180MC			672		562									
40	—	—	180LA	382	305	710	20	600	110	350	300	400	55	18.5	5.0	16	59.0
—	40	25, 30	180LC			710		600									
50, 60	—	—	200LA	420	342	770	20	660	110	400	350	450	55	18.5	5.0	16	59.0
—	50, 60	40, 50	200LC			800		140					60				
75	—	—	225SA	458	386	786.0	22	676.0	110	500	450	550	55	18.5	5.0	16	59.0
—	75	60	225SC			816.0		140					65				
100	—	—	250SA	510	479	890.5	22	780.5	110	500	450	550	55	18.5	5.0	16	59.0
—	100	75	250SC			920.5		140					75				
125	—	—	250MA	510	479	947.5	22	837.5	110	500	450	550	55	18.5	5.0	16	59.0
—	125	100	250MC			977.5		140					75				

Servo Motor Dimension 伺服馬達尺寸圖

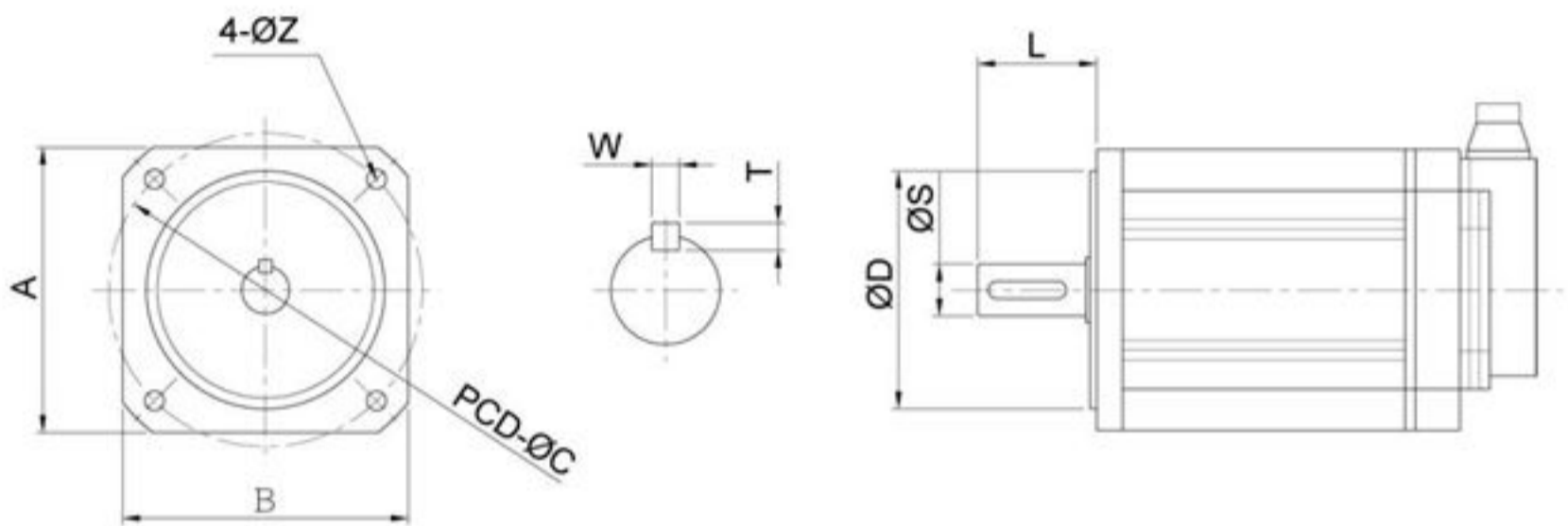

伺服馬達尺寸表 Servo Motor Dimension

適用型號 Applicable Model	代號 Code	Dimension (mm)								
		A	B	C	D	L	S	W	T	Z
200	24A-14	60	60	70	50	30	14	5	5	5.5
	24B-16	60	60	70	50	35	16	5	5	5.5
280	32A-14	60	60	70	50	30	14	5	5	5.5
	32A-16	60	60	70	50	35	16	5	5	5.5
	32B-14	80	80	90	70	30	14	5	5	5.5
	32B-16	80	80	90	70	35	16	5	5	5.5
	32B-19	80	80	90	70	40	19	5	5	9
	32C-16	112	112	100	80	35	16	5	5	6.5
	32D-19	132	132	145	110	58	19	5	5	9
	32D-22	132	132	145	110	58	22	6	6	9
300 (H)	38A-35	178	178	200	114.3	79	35	10	8	13.5
	38A-42	178	178	200	114.3	113	42	12	8	13.5
301 (H)	50A-35	178	178	200	114.3	79	35	10	8	13.5
	50A-42	178	178	200	114.3	113	42	12	8	13.5

註：本表所列尺寸為客戶經常性使用規格，其他特殊規格可另行指定配合承製，如安裝法蘭、特殊軸徑、軸長及鍵槽等，歡迎洽詢本公司相關業務人員。

Note: The dimensions listed in the table are the commonly used specifications by our customers. For other specialized specifications, customization can be made upon other assigned specifications, e.g., installation of flanges, specific shaft diameter, shaft length and key slots, etc. You are welcome to contact related sales staff of our company for details.



訂貨記號說明 *Products Selection*

範例 / EX

HF - 200 - 5.78 - 1/4 - H1

形式 Type	機型 Size	減速比 Ratio	馬力 Motor	安裝 Installation
	200	3.57	1/4HP	H1
	280	4.94	1/2HP	H2
	300	5.78	1HP	.
	301	7.09	2HP	.
	303	9.37	3HP	V1
.

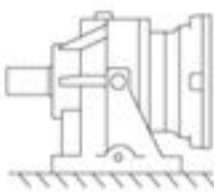
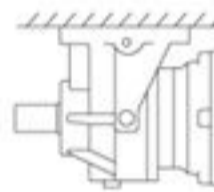
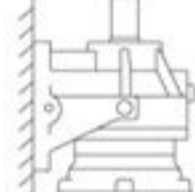
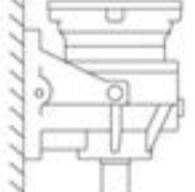
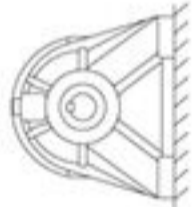
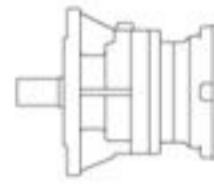
安裝方式 / Installation

H1 	H2 	H3 	H4 
H5 L(R) 	V1 	V2 	V3 

機型選用步驟 Model Selection Procedures

- 依貴公司設備自行計算出所需馬力數與需求減速比。
 - 在 P12 頁機型選用表內對照該馬力所配合之機型為何 (200~313) ?
 - 至 P13、14 頁找到該型號中之最接近比數，並查詢上方段數 (L1~4)。
 - 依選擇比數檢查該型號之最大受力值 ABC 是否符合設計值。
 - 當設計扭力超過該型號時，請選用更大機型。
 - 按照所需機型至 P15~18 選用安裝尺寸圖 (HF、VF、HS、VS)。
- Calculate the required power and reduction ratio according to the equipment of your company.
 - Refer to the Model Selection Table on Page 12 to select the model (200-313) that matches with the power.
 - Find the closest ratio of that model number on Pages 13 and 14 and check the number of steps (L1-4).
(For a special ratio, please contact our company.)
 - Per the selected ratio, check whether the maximum allowed force ABC of that model number meets the design value.
 - If the design torque exceeds that of the selected model number, please select a larger model.
 - Refer to Pages 15-18 for installation dimensional drawings (HF, VF, HS, VS) of the selected model.

Type Selection Table

機型選用

入力轉速 1750/1420 (60Hz/50Hz)

輸入馬力 INPUT HP	減速比範圍 RANGE OF RATIO	型號 SIZE
1/4HP	1/3.57~1/2936.8	200-L1, L2, L3
1/2HP	1/3.57~1/73.7	200-L1, L2
	1/87.1~1/221	280-L2, L3
	1/239~1/494	280-L3, L4
	1/503~1/1041	301-L4
1HP	1/3.48~1/116	280-L1,L2, L3
	1/131~1/221	300-L3
	1/239~1/616	301-L3, L4
	1/618~1/756	303-L4
	1/801~1/869	305-L4
2HP	1/906~1/2422	307-L4
	1/3.48~1/41.5	280-L1, L2
	1/51.8~1/177	300-L2, L3
	1/192~1/221	301-L3
3HP	1/230~1/456	305-L3, L4
	1/492~1/1591	307-L4
	1/3.48~1/7.2	280-L1
5HP	1/12.1~1/85	300-L2, L3
	1/90~1/134	303-L3
	1/136~1/184	305-L3
	1/188~1/546	307-L3, L4
7.5HP	1/603~1/1022	309-L4
	1/3.48~1/7.2	300-L1
	1/12.1~1/51.8	301-L2
	1/53~1/96.7	303-L3
	1/104~1/141	305-L3
	1/146~1/455	307-L3, L4
10HP	1/492~1/546	309-L4
	1/586~1/2186	313-L4
	1/3.48~1/7.2	301-L1
	1/12.5~1/54	303-L2
	1/63~1/107	305-L3
15HP	1/113~1/234	307-L3
	1/270~1/455	309-L3, L4
	1/501~1/2186	313-L4
	1/3.48~1/7.2	301-L1
	1/12.5~1/30.7	303-L2

輸入馬力 INPUT HP	減速比範圍 RANGE OF RATIO	型號 SIZE
20HP	1/3.6~1/7.5	303-L1
	1/12.5~1/43	305-L2
	1/46~1/125	307-L2, L3
	1/139~1/192	309-L3
	1/193~1/649	313-L3, L4
	1/3.6~1/7.5	305-L1
25HP	1/12.3~1/46	307-L2
	1/51~1/303	313-L3
30HP	1/3.6~1/7.5	305-L1
	1/12.3~1/46	307-L2
	1/51~1/303	313-L3
40HP	1/3.43~1/6.23	307-L1
	1/12.3~1/46	309-L2
	1/51~1/176	313-L3
50HP	1/3.43~1/6.23	307-L1
	1/12.3~1/46	309-L2
	1/51~1/176	313-L3
75HP	1/3.43~1/6.23	309-L1
	1/14.2~1/40.5	313-L2
100HP	1/3.43~1/6.23	309-L1
	1/14.2~1/40.5	313-L2
150HP	1/4.14~1/6.5	313-L1

輸入馬力 INPUT HP	減速比範圍 RANGE OF RATIO	型號 SIZE
20HP	1/3.6~1/7.5	303-L1
	1/12.5~1/43	305-L2
	1/46~1/125	307-L2, L3
	1/139~1/192	309-L3
	1/193~1/649	313-L3, L4
	1/3.6~1/7.5	305-L1
25HP	1/12.3~1/46	307-L2
	1/51~1/303	313-L3
30HP	1/3.6~1/7.5	305-L1
	1/12.3~1/46	307-L2
	1/51~1/303	313-L3
40HP	1/3.43~1/6.23	307-L1
	1/12.3~1/46	309-L2
	1/51~1/176	313-L3
50HP	1/3.43~1/6.23	307-L1
	1/12.3~1/46	309-L2
	1/51~1/176	313-L3
75HP	1/3.43~1/6.23	309-L1
	1/14.2~1/40.5	313-L2
100HP	1/3.43~1/6.23	309-L1
	1/14.2~1/40.5	313-L2
150HP	1/4.14~1/6.5	313-L1

徑向負荷與推力最大容許值(kg) Max. Load Of Radial And Axis (Kg)

型號 SIZE	R1	R2	R3	F1	F2
200	1000	600	420	950	600
280	1360	800	560	1100	800
300	1900	1100	750	2000	1500
300H	1900	1100	750	2000	1500
301	1900	1100	750	2000	1500
301H	1900	1100	750	2000	1500
303	6000	3800	2800	5500	4400
305	6000	3800	2800	5500	4400
307	9500	4500	3500	9000	5000
309	17000	11000	8000	10000	6000
313	32000	21000	16000	20000	15000

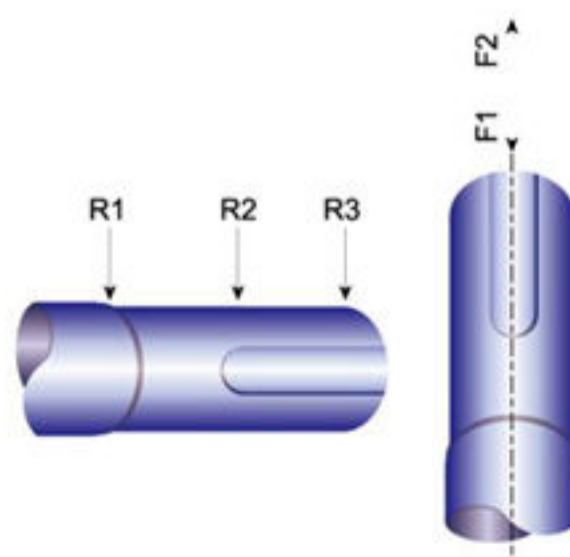



入力轉數為 1750 rpm (INPUT WITH 1750 RPM)

型號 Size	L1		L2				L3						L4						最大承受扭力 MAX. OUTPUT TORQUE (kg-m)
	一段減速比	最大輸入馬力	二段減速比	最大輸入馬力	二段減速比	最大輸入馬力	三段減速比	最大輸入馬力	三段減速比	最大輸入馬力	三段減速比	最大輸入馬力	四段減速比	最大輸入馬力	四段減速比	最大輸入馬力	四段減速比	最大輸入馬力	
	1 STAGE	(A)	2 STAGE	(A)	2 STAGE	(A)	3 STAGE	(A)	3 STAGE	(A)	3 STAGE	(A)	4 STAGE	(A)	4 STAGE	(A)	4 STAGE	(A)	
200	3.57	C 0.5	12.75	C 0.5	50.3	C 0.5	45.5	C 0.5	165	A 0.25	313	B 0.25	311	B 0.25	855	A 0.25	1809	C 0.25	A 28
	4.94	A 0.5	17.6	A 0.5	54.16	C 0.5	63	C 0.5	173	A 0.25	356.4	C 0.25	364	B 0.25	954	B 0.25	1897	C 0.25	
	5.78	B 0.5	20.6	B 0.5	66.4	C 0.5	73.7	C 0.5	179.5	C 0.25	383.9	C 0.25	426	B 0.25	1000	A 0.25	2060	C 0.25	
	7.09	C 0.5	24.4	A 0.5	87.8	C 0.5	87.1	A 0.25	193.1	B 0.25	433.7	B 0.25	504	A 0.25	1116	B 0.25	2143	B 0.25	B 20
	9.37	C 0.5	25.3	C 0.5			90.4	C 0.25	202.4	A 0.25	471	C 0.25	522	C 0.25	1227	A 0.25	2219	C 0.25	
			28.5	A 0.5			101.9	A 0.25	228.7	A 0.25	507.5	C 0.25	596	A 0.25	1322	A 0.25	2326	C 0.25	
			33.4	C 0.5			120.5	A 0.25	236.9	B 0.25	622.5	C 0.25	641	C 0.25	1435	C 0.25	2527	C 0.25	C 17
			35	A 0.5			125	B 0.25	248.3	B 0.25	822.6	C 0.25	697	B 0.25	1546	C 0.25	2937	C 0.25	
			41	B 0.5			141	A 0.25	267.5	A 0.25			723	B 0.25	1679	C 0.25	4754	B 0.25	
		46.3	B 0.5			146.3	B 0.25	290.5	C 0.25			815	B 0.25	1760	C 0.25	7708	C 0.25		
280	3.48	C 3	12.1	C 2	51.8	C 1	52	A 2	116	A 1	299	B 0.25	403	B 0.25	628	C 0.25	1108	B 0.25	A 60
	4.26	A 3	14.8	A 2			63	A 2	131	A 0.5	373	C 0.25	446	A 0.25	669	B 0.25	1274	A 0.25	
	5.77	B 3	18.1	A 2			69	B 1	141	A 0.5			454	A 0.25	754	A 0.25	1299	C 0.25	
	7.2	C 3	20	B 2			77	A 1	144	A 0.5			494	B 0.25	818	A 0.25	1383	B 0.25	B 45
			24.6	A 2			85	A 1	177	A 0.5			503	B 0.25	834	B 0.25	1590	A 0.25	
			30.7	A 2			87.2	C 1	192	B 0.5			557	A 0.25	940	A 0.25	1726	B 0.25	
			33.3	B 2			104	A 1	221	A 0.5			604	A 0.25	1021	A 0.25	2154	B 0.25	C 35
		41.5	B 2			106	A 1	239	B 0.25			616	B 0.25	1041	B 0.25	2687	C 0.25		
300 300H	3.48	C 7.5	12.1	C 3	51.8	C 3	52	A 3	116	A 2	299	B 0.5	403	B 0.5	628	C 0.25	1108	B 0.25	A 120
	4.26	A 7.5	14.8	A 3			63	A 3	131	A 2	373	C 0.25	446	A 0.5	669	B 0.25	1274	A 0.25	
	5.77	B 7.5	18.1	A 3			69	B 3	141	A 2			454	A 0.5	754	A 0.25	1299	C 0.25	
	7.2	C 7.5	20	B 3			77	A 3	144	A 2			494	B 0.25	818	A 0.25	1383	B 0.25	B 90
			24.6	A 3			85	A 3	177	A 2			503	B 0.25	834	B 0.25	1590	A 0.25	
			30.7	A 3			87.2	C 2	192	B 1			557	A 0.25	940	A 0.25	1726	B 0.25	
			33.3	B 3			104	A 2	221	A 1			604	A 0.25	1021	A 0.25	2154	B 0.25	C 70
		41.5	B 3			106	A 2	239	B 0.5			616	B 0.25	1041	B 0.25	2687	C 0.25		
301 301H	3.48	C 15	12.1	C 7.5	51.8	C 7.5	52	A 5	116	A 3	299	B 1	403	B 1	628	C 0.5	1108	B 0.25	A 240
	4.26	A 15	14.8	A 7.5			63	A 5	131	A 3	373	C 1	446	A 1	669	B 0.5	1274	A 0.25	
	5.77	B 15	18.1	A 7.5			69	B 5	141	A 3			454	A 1	754	A 0.5	1299	C 0.25	
	7.2	C 15	20	B 7.5			77	A 5	144	A 3			494	B 1	818	A 0.5	1383	B 0.25	B 185
			24.6	A 7.5			85	A 5	177	A 3			503	B 1	834	B 0.5	1590	A 0.25	
			30.7	A 7.5			87.2	C 3	192	B 2			557	A 1	940	A 0.5	1726	B 0.25	
			33.3	B 7.5			104	A 3	221	A 3			604	A 1	1021	A 0.5	2154	B 0.25	C 155
		41.5	B 7.5			106	A 3	239	B 1			616	B 1	1041	B 0.5	2687	C 0.25		
303	3.6	C 20	12.5	C 15	43	B 10	53	A 7.5	112	C 5	190	C 2	412	B 1	962	B 0.5	1989	B 0.25	A 320
	4.25	A 20	15.3	A 15	44.6	C 10	63	A 7.5	124	C 5	221	B 2	456	B 1	1024	B 0.5	2244	D 0.25	
	5.33	B 20	18.1	A 15	54	D 10	72	A 7.5	131	B 5	230	C 2	524	D 1	1084	D 0.25	2799	D 0.25	
	6.2	C 20	20.8	A 15			77	A 7.5	134	B 5	258	C 1	558	B 1	1177	B 0.25			B 280
	7.5	D 20	22.7	B 15			79	B 7.5	136	C 3	276	B 1	618	B 1	1278	B 0.25			
			24.5	A 15			85	A 7.5	141	A 3	311	C 1	654	D 1	1327	D 0.25			
			26.4	D 15			90	B 7.5	150	C 3	321	C 1	696	B 1	1440	D 0.25			C 245
			30.7	B 15			96.7	B 7.5	163	B 3	388	D 1	756	B 1	1594	B 0.25			
			35.8	C 10			104	A 5	177	B 3			801	D 0.5	1656	D 0.25			
		38.4	B 10			107	B 5	184	C 3			869	D 0.5	1798	D 0.25			D 210	



入力轉數為 1750 rpm (INPUT WITH 1750 RPM)

型號 Size	L1		L2				L3						L4						最大承受扭力 MAX. OUTPUT TORQUE (kg-m)
	一段減速比	最大輸入馬力	二段減速比	最大輸入馬力	二段減速比	最大輸入馬力	三段減速比	最大輸入馬力	三段減速比	最大輸入馬力	三段減速比	最大輸入馬力	四段減速比	最大輸入馬力	四段減速比	最大輸入馬力	四段減速比	最大輸入馬力	
	1 STAGE	(A)	2 STAGE	(A)	2 STAGE	(A)	3 STAGE	(A)	3 STAGE	(A)	3 STAGE	(A)	4 STAGE	(A)	4 STAGE	(A)	4 STAGE	(A)	
305	3.6	C 30	12.5	C 20	43	B 20	53	A 10	112	C 7.5	190	C 3	412	B 2	962	B 0.5	1989	B 0.5	A 630
	4.25	A 30	15.3	A 20	44.6	C 15	63	A 10	124	C 7.5	221	B 3	456	B 2	1024	B 0.5	2244	D 0.5	
	5.33	B 30	18.1	A 20	54	D 15	72	A 10	131	B 7.5	230	C 3	524	D 1	1084	D 0.5	2799	D 0.5	B 550
	6.2	C 30	20.8	A 20			77	A 10	134	B 7.5	258	C 3	558	B 1	1177	B 0.5			
	7.5	D 30	22.7	B 20			79	B 10	136	C 5	276	B 3	618	B 1	1278	B 0.5			C 470
			24.5	A 20			85	A 10	141	A 7.5	311	C 2	654	D 1	1327	D 0.5			
			26.4	D 20			90	B 10	150	C 5	321	C 2	696	B 1	1440	D 0.5			
			30.7	B 20			96.7	B 10	163	B 5	388	D 2	756	B 1	1594	B 0.5			
		35.8	C 20			104	A 10	177	B 5			801	D 1	1656	D 0.5			D 410	
		38.4	B 20			107	B 10	184	C 5			869	D 1	1798	D 0.5				
307	3.43	C 50	12.3	C 30	46	C 30	43	A 20	125	B 20	202	B 10	396	A 7.5	848	C 3	1721	C 1	A 1525
	4.09	A 50	14.7	A 30			50	A 20	139	C 15	221	A 10	455	A 7.5	906	A 3	1941	C 1	
	5.25	B 50	17.4	A 30			60	A 20	146	C 15	227	B 10	492	C 5	941	A 3	2002	C 1	B 1245
	6.23	C 50	18.9	B 30			63	A 20	152	B 15	234	B 10	546	A 5	1022	A 3	2422	C 1	
			21.8	B 30			77	B 20	157	A 15	270	C 7.5	603	C 3	1106	C 2			
			25.4	C 30			80	B 20	163	C 15	278	C 7.5	669	A 3	1130	A 2			
			27.9	B 30			89	A 20	177	B 15	284	C 7.5	693	C 3	1149	C 2			
			30.7	C 30			93	A 20	188	B 15	336	C 7.5	755	A 3	1275	A 2			
		32.5	C 30			100	A 20	192	B 15			769	A 3	1433	C 2			C 1075	
		38	C 30			113	C 20	199	C 10			816	C 3	1591	A 2				
309	3.43	C 100	12.3	C 50	46	C 50	43	A 20	125	B 20	202	B 15	396	A 10	848	C 5	1721	C 2	A 2250
	4.09	A 100	14.7	A 50			50	A 20	139	C 20	221	A 15	455	A 10	906	A 5	1941	C 2	
	5.25	B 100	17.4	A 50			60	A 20	146	C 20	227	B 15	492	C 7.5	941	A 5	2002	C 2	B 1800
	6.23	C 100	18.9	B 50			63	A 20	152	B 20	234	B 15	546	A 7.5	1022	A 5	2422	C 2	
			21.8	B 50			77	B 20	157	A 20	270	C 10	603	C 5	1106	C 3			
			25.4	C 50			80	B 20	163	C 20	278	C 10	669	A 5	1130	A 3			
			27.9	B 50			89	A 20	177	B 20	284	C 10	693	C 5	1149	C 3			
			30.7	C 50			93	A 20	188	B 20	336	C 10	755	A 5	1275	A 3			
		32.5	C 50			100	A 20	192	B 20			769	A 5	1433	C 3			C 1600	
		38	C 50			113	C 15	199	C 15			816	C 5	1591	A 3				
313	4.14	A 150	14.2	A 100	28.3	B 100	51	A 50	110	A 50	181	C 30	335	A 20	706	B 15	1035	B 10	A 6500
	5.4	B 150	16.9	A 100	33.6	B 100	61	A 50	120	B 50	193	A 30	381	A 20	793	A 15	1192	B 10	
	6.5	C 150	18.5	B 100	34.1	C 100	71	A 50	135	B 50	208	B 30	501	B 20	847	B 15	1393	A 10	B 5000
			21.7	B 100	40.5	B 100	78	A 50	143	B 50	252	B 30	541	A 20	914	A 15	1817	B 10	
			25.8	B 100			92	A 50	151	B 50	303	C 30	586	A 20	956	B 15	2186	B 10	C 4100
		26.6	C 100			105	A 50	176	B 50			649	A 20	990	A 15				

* 依您需要的減速比及轉矩來對照每一段減速比上的ABC最大受力值，及最大輸入馬力。

Please determine your ratio and output torque to match each code of gear stages A, B & C. and find different maximum torque & input capacity.

例：
 型號 280，一段齒5.77比(B)在對照右側最大受力表，其(B)最大受力為45kg-m，最大可輸入馬力3HP。

Example : Type 280#, Ratio 1/5.77
 Gear Stage Code : (B)
 Max Torque : 45 Kg-M
 Max Input Hp : 3Hp

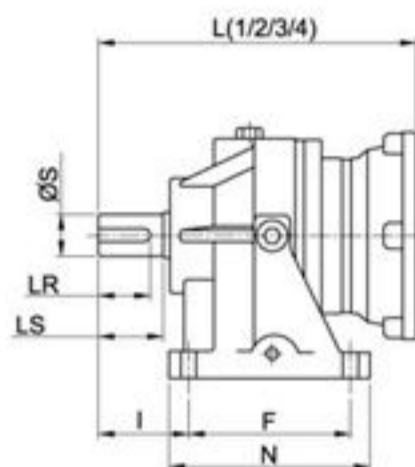
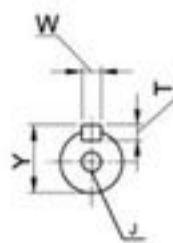
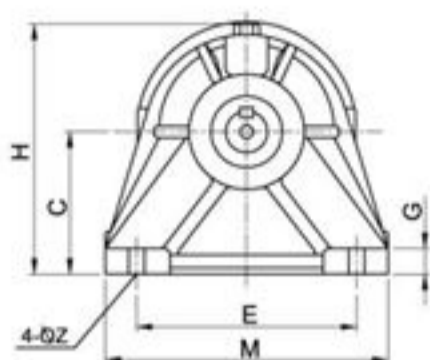

尺寸規格表 DIM.TABLE (mm)

Size	腳座 Foot									出力軸 Output Shaft			鍵 Key				馬達框號 IEC規格 MOTOR FRAME
	C	E	F	G	H	I	M	N	Z	LR	LS	S	J	T	W	Y	
200	90	140	90	13	150	53	165	120	4-12	30	35	24	M8	7	8	27	63A-71B
280	110	170	125	20	185	69.5	210	155	4-12	40	50	32	M10	8	10	35	71B-90L
300	140	200	160	25	233	78	260	200	4-18	50	58	38	M12	8	10	41	71B-112M
300H	190	200	160	25	283	78	260	200	4-18	50	58	38	M12	8	10	41	132L
301	140	200	160	25	233	104	260	200	4-18	70	82	50	M16	9	14	53.5	90L-160L
301H	190	200	160	25	283	104	260	200	4-18	70	82	50	M16	9	14	53.5	132L-160M
303	210	300	250	35	332	128	370	305	4-22	80	95	55	M16	10	16	59	90L-160L
305	210	300	250	35	332	138	370	305	4-22	90	105	60	M20	11	18	64	90L-180L
307	250	365	356	45	425	175	445	436	4-28	110	130	80	PCD-55 3-M12	14	22	85	100LA-200L
309	250	365	356	45	425	215	445	436	4-28	150	170	90	PCD-55 3-M12	14	25	95	100LA-225S
313	280	457	470	35	503	291	560	626.5	4-28	180	200	120	PCD-70 3-M16	18	32	127	200LA-280S

L長度表 LENGTH TABLE (mm)

一段式 Stage 1												
型號 馬力	Size HP	200	280	300	300(H)	301	301(H)	303	305	307	309	313
1/4, 1/2	L1	176	236	*	*	*	*	*	*	*	*	*
1, 2		*	236	278	278	316	316	*	*	*	*	*
3, 5		*	246	280	280	318	318	412.5	422.5	*	*	*
7.5, 10		*	*	295	295	333	333	427.5	437.5	*	*	*
15, 20		*	*	*	*	369	369	463.5	473.5	*	*	*
25, 30		*	*	*	*	*	*	463.5	473.5	*	*	*

二段式 Stages 2												
型號 馬力	Size HP	200	280	300	300(H)	301	301(H)	303	305	307	309	313
1/4, 1/2	L2	206	270	308	308	*	*	*	*	*	*	*
1, 2		*	270	308	308	358	358	437	447	*	*	*
3, 5		*	280	318	318	360	360	439	449	639.5	679.5	*
7.5, 10		*	*	*	*	375	375	454	464	654.5	694.5	*
15, 20		*	*	*	*	423	423	490	500	690.5	730.5	*
25, 30		*	*	*	*	*	*	*	*	690.5	730.5	*

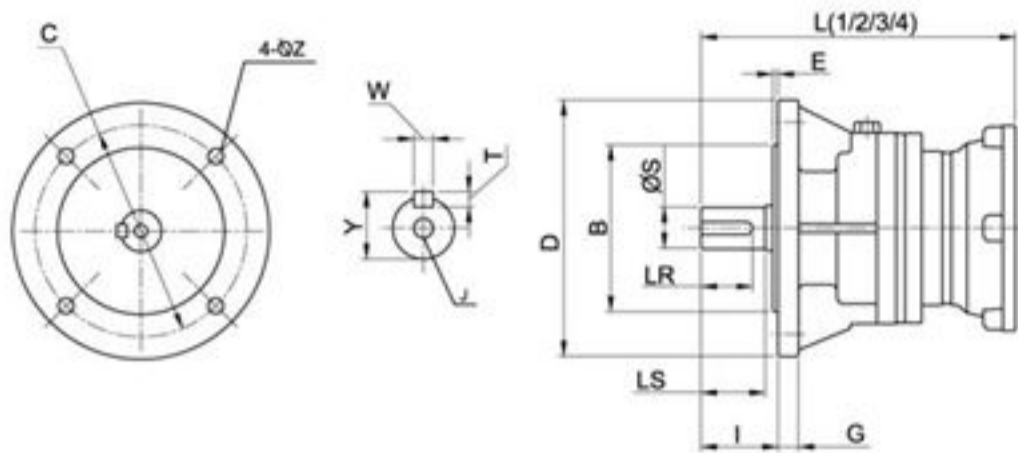

尺寸規格表 DIM.TABLE (mm)

Size	出力法蘭 Output Flange							出力軸 Output Shaft			鍵 Key				馬達框號 IEC規格 MOTOR FRAME
	B	C	D	E	G	I	Z	LR	LS	S	J	T	W	Y	
200	110	130	160	4	12	44	4-10	30	35	24	M8	7	8	27	63A-71B
280	130	165	200	4	16	60	4-12	40	50	32	M10	8	10	35	71B-90L
300	180	215	250	4	20	68	4-16	50	58	38	M12	8	10	41	71B-112M
300H	230	265	300	4	20	68	4-16	50	58	38	M12	8	10	41	132L
301	180	215	250	4	20	94	4-16	70	82	50	M16	9	14	53.5	90L-160M
301H	230	265	300	4	20	94	4-16	70	82	50	M16	9	14	53.5	132L-160M
303	250	300	350	4	20	104	4-19	80	95	55	M16	10	16	59	90L-160L
305	250	300	350	4	20	114	4-19	90	105	60	M20	11	18	64	90L-180L
307	350	400	450	5	27	140	4-22	110	130	80	PCD-55 3-M12	14	22	85	100LA-200L
309	350	400	450	5	27	180	4-22	150	170	90	PCD-55 3-M12	14	25	95	100LA-225S
313	450	500	550	5	32	214.5	8-28	180	200	120	PCD-70 3-M16	18	32	127	200LA-280S

L長度表 LENGTH TABLE (mm)

三段式 Stages 3												
型號 馬力	Size HP	200	280	300	300(H)	301	301(H)	303	305	307	309	313
1/4, 1/2	L3	236	304	342	342	388	388	*	*	*	*	*
1, 2		*	304	342	342	388	388	479	489	664	704	*
3, 5		*	314	352	352	398	398	481	491	666	706	*
7.5, 10		*	*	*	*	*	*	496	506	681	721	1051.5
15, 20		*	*	*	*	*	*	544	554	717	757	1087.5
25, 30		*	*	*	*	*	*	*	*	*	*	1087.5

四段式 Stages 4												
型號 馬力	Size HP	200	280	300	300(H)	301	301(H)	303	305	307	309	313
1/4, 1/2	L4	266	338	376	376	422	422	509	519	*	*	*
1, 2		*	338	376	376	422	422	509	519	706	746	1061
3, 5		*	348	386	386	432	432	519	529	708	748	1063
7.5, 10		*	*	*	*	*	*	*	*	723	763	1078
15, 20		*	*	*	*	*	*	*	*	771	811	1114
25, 30		*	*	*	*	*	*	*	*	*	*	*

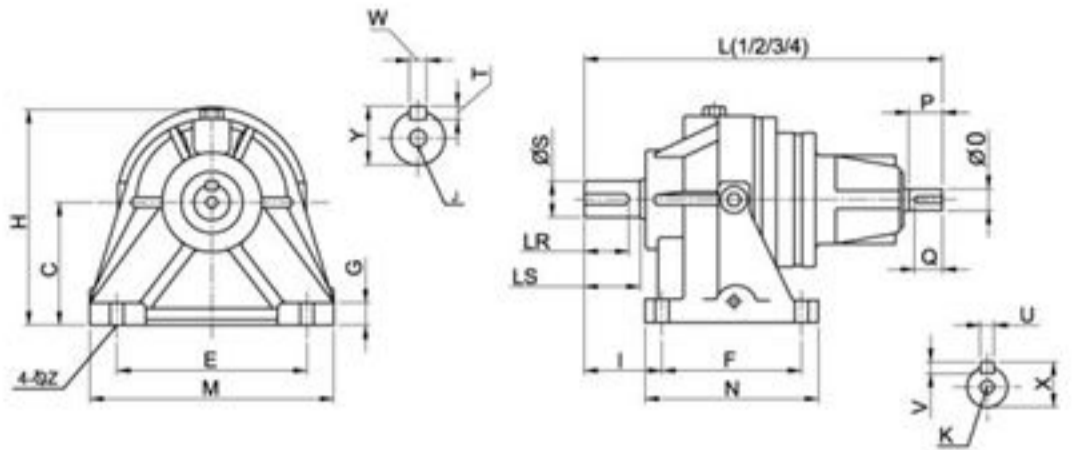

尺寸規格表 DIM.TABLE (mm)

Size	腳座 Foot									出力軸 Output Shaft			鍵 Key			
	C	E	F	G	H	I	M	N	Z	LR	LS	S	J	T	W	Y
200	90	140	90	13	150	53	165	120	4-12	30	35	24	M 8	7	8	27
280	110	170	125	20	185	69.5	210	155	4-12	40	50	32	M 10	8	10	35
300	140	200	160	25	233	78	260	200	4-18	50	58	38	M 12	8	10	41
300H	190	200	160	25	283	78	260	200	4-18	50	58	38	M 12	8	10	41
301	140	200	160	25	233	104	260	200	4-18	70	82	50	M 16	9	14	53.5
301H	190	200	160	25	283	104	260	200	4-18	70	82	50	M 16	9	14	53.5
303	210	300	250	35	332	128	370	305	4-22	80	95	55	M 16	10	16	59
305	210	300	250	35	332	138	370	305	4-22	90	105	60	M 20	11	18	64
307	250	365	356	45	425	175	445	436	4-28	110	130	80	PCD-55 3-M12	14	22	85
309	250	365	356	45	425	215	445	436	4-28	150	170	90	PCD-55 3-M12	14	25	95
313	280	457	470	35	503	291	560	626.5	4-28	180	200	120	PCD-70 3-M16	18	32	127

L長度表 LENGTH TABLE (mm)

一段式 Stage 1								
Size	L1	入力軸 Input Shaft			鍵 Key			
		O	P	Q	K	U	V	X
200	252	19	30	20	M 6	6	6	21.5
280	297	24	40	35	M 8	8	7	27
300H	362	38	58	45	M 10	10	8	41
301H	400	38	58	45	M 10	10	8	41
303	502.5	50	82	70	M 12	14	9	53.5
305	512.5	50	82	70	M 12	14	9	53.5
307	705	60	105	90	M 14	18	11	64
309	745	60	105	90	M 14	18	11	64
313		80	130	110	PCD-55 3-M12	22	14	85

二段式 Stages 2								
Size	L2	入力軸 Input Shaft			鍵 Key			
		O	P	Q	K	U	V	X
200	282	19	30	20	M 6	6	6	22
280	331	24	40	35	M 8	8	7	27
300H	369	24	40	35	M 8	8	7	27
301H	442	38	58	45	M 10	10	8	41
303	521	38	58	45	M 10	10	8	41
305	531	38	58	45	M 10	10	8	41
307	729.5	50	82	70	M 12	14	9	54
309	769.5	50	82	70	M 12	14	9	54
313	1102	60	105	90	M 14	18	11	64

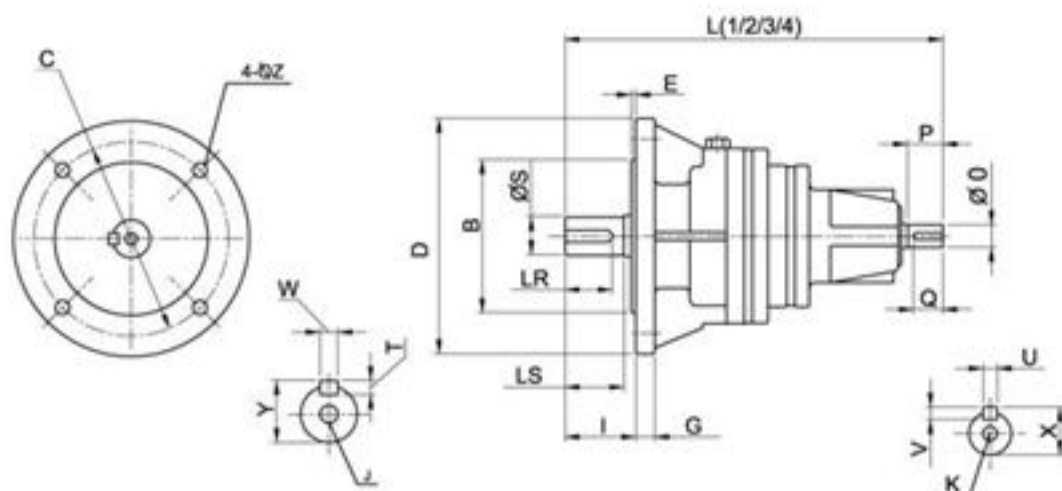

尺寸規格表 DIM.TABLE (mm)

Size	出力法蘭 Output Flange							出力軸 Output Shaft			鍵 Key			
	B	C	D	E	G	I	Z	LR	LS	S	J	T	W	Y
200	110	130	160	4	12	44	4-10	30	35	24	M8	7	8	27
280	130	165	200	4	16	60	4-12	40	50	32	M10	8	10	35
300	180	215	250	4	20	68	4-16	50	58	38	M12	8	10	41
300H	230	265	300	4	20	68	4-16	50	58	38	M12	8	10	41
301	180	215	250	4	20	94	4-16	70	82	50	M16	9	14	53.5
301H	230	265	300	4	20	94	4-16	70	82	50	M16	9	14	53.5
303	250	300	350	4	20	104	4-19	80	95	55	M16	10	16	59
305	250	300	350	4	20	114	4-19	90	105	60	M20	11	18	64
307	350	400	450	5	27	140	4-22	110	130	80	PCD-55 3-M12	14	22	85
309	350	400	450	5	27	180	4-22	150	170	90	PCD-55 3-M12	14	25	95
313	450	500	550	5	32	214.5	8-28	180	200	120	PCD-70 3-M16	18	32	127

L長度表 LENGTH TABLE (mm)

三段式 Stages 3								
Size	L3	入力軸 Input Shaft			鍵 Key			
		O	P	Q	K	U	V	X
200	312	19	30	20	M6	6	6	21.5
280	365	24	40	35	M8	8	7	27
300H	403	24	40	35	M8	8	7	27
301H	449	24	40	35	M8	8	7	27
303	563	38	58	45	M10	10	8	41
305	573	38	58	45	M10	10	8	41
307	748	38	58	45	M10	10	8	41
309	788	38	58	45	M10	10	8	41
313	1126.5	50	82	70	M12	14	9	53.5

四段式 Stages 4								
Size	L4	入力軸 Input Shaft			鍵 Key			
		O	P	Q	K	U	V	X
200	342	19	30	20	M6	6	6	21.5
280	399	24	40	35	M8	8	7	27
300H	437	24	40	35	M8	8	7	27
301H	483	24	40	35	M8	8	7	27
303	570	24	40	35	M8	8	7	27
305	580	24	40	35	M8	8	7	27
307	790	38	58	45	M10	10	8	41
309	830	38	58	45	M10	10	8	41
313	1145	38	58	45	M10	10	8	41